

STEENBECK USER MANUAL 35mm 01-SERIES



Compact sized flatbed editors:

- ST3511 2 plate, COMOPT sound.
for 600 meters / 2000 feet of film.
- ST1401 4 plate, COMOPT and 1 track SEPMAG sound.
for 600 meter / 2000 feet of film and perforated tape.
- ST401 4 plate, COMOPT and 1 track SEPMAG sound.
for 600 meter / 2000 feet of film and perforated tape.
picture-sound shift system for 1 track.

Larger sized flatbed editors:

- ST701 6 plate, COMOPT and 2 tracks SEPMAG sound.
for 600 meter / 2000 feet of film and perforated tape.
picture-sound shift system for 2 tracks.
- ST721 6 or 8, plate version with 2 picture system.
standard with one COMOPT and 2 tracks SEPMAG sound.
depending on version from 350 meter / 1200 feet up to
600 meter / 2000 feet of film and perforated tape.
picture-sound shift system for 2 tracks.
8 plate version can have 4 plates of 600 meter/2000 feet.

Copyright © 1978 – 2013.
Steenbeck is a trademark.
No part of this manual may be reproduced without the prior written permission of Steenbeck.
Specifications, colours etc. are subject to change without notice. Images are an example.

Table of contents user manual:

Section	page
0.0 Table of contents	1-2
1.0 Introduction	3
2.0 General data	3
3.0 Technical data :	
3.1.1. introduction	4
3.1.2. film plates / film reels / cores	4
3.1.3 shrunken material	4
3.1.4 frictions	4
3.2 picture	5
3.3 sound	5
3.4 general technical information	6
4.0 Important safety and warranty information	
4.1 safety	7
4.2 warranty	8
fig. 1 general overview	9
fig. 2 switch board	10
fig. 3 sound preamplifier section	10
fig. 4 fuse panel	10
fig. 5 drive deck overview	11
5.0 How to use the 35mm 01-Series:	
5.1 general overview	12
5.2 switch board and pressure switches	12
5.3 sound preamplifier section	12
5.4 drive deck	13
5.5 fuse panel	13
5.6 connecting to mains power	14
5.7 threading film and sound tape	14
5.8 rewind	15
5.9 sound	15
6.0 Universal counter /display	16
Picture - sound shift system (ST401-ST701-ST721 only)	17

7.0	Connection loudspeakers and (optional) working lamp	18
8.0	Maintenance instructions :	
	8.1 introduction	19
	8.2 replacing picture lamp	20
	8.3 replacing exciter/optical lamp	20
	8.4 adjustment pressure arms picture	20
	8.5 surface-coated mirrors	20
	8.6 polygon and lens	20
	8.7 screen	21
	8.8 illumination system	21
	8.9 frictions	21-22
	8.10 general maintenance	22
	8.11 adjustment guide ring 16mm	23
9.0	List op slow and fast moving spare parts 35mm 01-Series	24
10.0	Operation field table top:	
	10.1 ST3511	25
	10.2 ST401 ST1401	26
	10.2 ST701	27
	10.3 ST721	28
11.0	Adjustment picture lamp 35mm (all models)	29
12.0	Threading film and perforated magnetic sound (MAG) tape	
	ST3511 picture only	30
	picture with COMOPT sound	30
	ST401 / 1401 picture w/o sound / w MAG sound	31
	picture w sound	31
	picture w COMMAG	32
	ST701 picture with COMOPT sound	33
	picture w/o sound / w MAG sound	33
	ST721 picture with COMOPT sound	34
	picture L w sound / w MAG sound	34
	pictures ST701 and ST721	35

1.0 INTRODUCTION:

The 35mm 01-Series film editing, viewing and controlling tables, is for many years a solid proven concept for film archives, film laboratories etc..

Working with this table is comfortable. With a minimum of physical effort the film can be checked in a fast and accurate manner, the metadata is noted and the film is prepared for possible scanning.

This manual shows the way to use all the possibilities of this 35mm 01-Series film table.

Caution: since the introduction of the 01 series many electronically / mechanically developments and improvements have been made. Be aware that the type number never have been changed since and therefor new and/or old parts/electronics not always been interchangeable.

2.0 GENERAL DATA:

- for 35mm film, with COMOPT (optical) sound.
- 2 plate version up to 8 plate with SEPMAG sound.
- fast and accurate checking / viewing film.
- halogen lamp 12 Volt / 100 watt.
- high quality projection screen.
- digital processor counter.
- display for actual speed of the film (optional)
- Sound system:
 - each preamp with fader
 - summing amp.: with treble, bass and master volume potential meter
 - ¼" head phone jack
 - two way high quality speakers.
- switchable sync speeds 24 and 25 f.p.s. (frames per second)
- variable speed from 0 till 100 f.p.s. (approx.) (option ST200)
- standard for film cores.
- ground glass, back illuminated.
- dimmer for working lamp (option ST57).
- operating voltage selectable 100 – 240 Volt / 50 of 60Hz at 6 /10 Amp

3.0 TECHNICAL DATA:

3.1 DRIVE SYSTEM.

3.1.1 Introduction:

The Steenbeck 01-Series has a proven 1 motor drive technology.

The table runs smoothly, because of the famous Steenbeck 'speed switch'.

This speed switch has fixed points for sync (synchronous 24 of 25 frames per second f.p.s.) forward and reverse, and adjustable notches between sync en maximum speed. (approx. 50 f.p.s., forward and reverse selectable by user).

The maximum speed can also be adjusted to approx. 100 f.p.s.

The maximum for both directions can be a little different.

3.1.2 Film plates / cores:

Depending on version the film plates are for approx. 400 meter / 1300 feet of film up to 600 meter / 2000 feet of film with cores/bobbins according to DIN 15531.

The winding tension of the plates can be adjusted.

3.1.3 Shrunken material:

The standard supplied sprocket rings are made to be used also for slightly shrunken film material. If the film is in a bad condition (very stretched or shrunken) it is advisable to change the sprocket ring at the polygon, otherwise the film can be damaged.

For shrunken film with sound the COMOPT sprocket should also be replaced by a shrunken one.

We also have sprockets for shrunken SEPMAG perforated tape.

See options for the correct stock numbers in case of ordering.

3.1.4 Frictions:

The frictions are fitted with core holders for use of film cores.

It is recommended to use film bobbins/cores of 100mm diameter.

3.2 PICTURE.

The rear screen projection method via an optical compensation system is done with 18-face revolving prism (polygon). With the high quality surface mirrors, optics and screen material gives this a very brilliant, bright and sharp image.

The standard dimensions of the projection are 212 x 288 mm.

Accurate film transport is achieved by revolving sprockets .

The picture lamp can easily be replaced and adjusted.

In stand-still mode the light is automatically dimmed to prevent heat damages to the film. The easy threading of film and perforated tape saves time and protect the film from being damaged. (see pages 29 - 32)

Option ST92: Cinemascope

3.3 SOUND.

High quality sound reproduction is done by plug-in pre-amplifiers.

All sound is mono, however stereo SEPMAG is optional available.

COMMAG sound mono is optional available.

ST3511: COMOPT, mono

ST(1)401: COMOPT, mono 1 track of SEPMAG (mono)

ST701 COMOPT, mono 2 track of SEPMAG (mono)

ST721: 1x COMOPT, mono 2 track of SEPMAG (mono)

-summing amplifier with: treble / bass / master volume adjust.
head phone output with ¼" jack.

-2 loudspeakers 2 way, 2 x 30 watt.

The so called synchronize points for film and PE sound film (perforated tape) are only available on request as an option.

3.4 GENERAL DATA.

Power: 1 phase 100 – 240 Volts - 50 / 60 Hz.
 Power consumption: approx. 800 – 1000 W. (depending on version)
 Switch on current: 10 Amps. (at 230 V)
 The fuses (5x20mm) 100 – 120 Volt 10 Amp T and 0,5 Amp T.
 220 – 240 Volt 6,3 Amp T and 0,5 Amps T

The fuses can be found on the back side of the machine. (see fig. 4 page 10)

Important: all fuses in the Steenbeck 01-Series are **T** (slow blown) and should never be replaced by F (fast blown) fuses.

Sizes of a complete table incl. monitor and speakers:
 ST3511 – ST(1)401; compact sized editors:

width	120 cm
working height	80 cm
depth, incl. monitor	99 cm
total height	129 cm

Weight 150 kg up to 160 kg.

ST701 – ST721; large sized editors:

width	152 cm
working height	80 cm
depth, incl. monitor	109 cm
total height	129 cm

Weight 200 kg up to 230 kg.

4.0 IMPORTANT SAFETY AND WARRANTY INFORMATION.

4.1 SAFETY:

The installation and maintenance should always be done by Steenbeck factory engineers or an appointed /certified Steenbeck agent / dealer.

Of highest importance is a **well-connected** and **safe power ground system**.

This system has to be in a 100% condition, because of:

- the safety of the user of the Steenbeck 01-Series
- the risk of electronically malfunction both inside and outside the table.
- discharge of static electricity.

The 01-Series should always be placed in a dry room and free from dust.

The temperature should be between 5° C and 40° C (40°F 105°F)

Humidity should be between 30% to 70% (approx.).

A higher humidity can cause corrosion on electronic contacts.

Warning: never put drinks / liquids on the Steenbeck machine.

Liquid spill, when leaking into the machine, can cause great damage and can be dangerous for its user.

Regularly clean the machine with the brush and the special cleaning wipes (blue is for wet use and yellow is for dry cleaning). Never use steel cleaning tools.

Never open the machine.

If there is any mechanical or electronically alignment needed, these should be done by a Steenbeck engineer or by Steenbeck trained staff.

It's advised to use good trained staff to work with the Steenbeck machine.

It's very important that this personnel has read and studied the user manual.

IMPORTANT:

There is always a personal danger related to the revolving sprockets.

Beware of this danger when having long hair, necklaces, bracelets, long sleeves etc.

4.2 WARRANTY INFORMATION:

STEENBECK film machines are made with the best possible accuracy and precision. Extensive runs and tests are done on the machine prior to shipment.

STEENBECK film machines are built to achieve maximum quality, reliability, and long life resulting in a minimum of maintenance.

There is always the possibility that within the warranty period of 1 (one) year, after purchasing the Steenbeck, a part is not working properly.

In such case, please contact the Steenbeck factory or your local Steenbeck agent/dealer at once.

Defective parts will be repaired or replaced by Steenbeck.

Before replacing the part, Steenbeck has the right to check the part before replacing it.

No warranty in case of:

- the machine is used for a different purpose than what it was made for.
- deliberate damage.
- an untrained technician has worked at the machine.
- defective projection or optical sound lamp, wire breakage.
- damage the lacquer by use, bumping or cleaning with not advised solvent.

Defective parts should be send to the Steenbeck factory in Holland or the local agent/dealer at cost and risk of the owner/user of the Steenbeck machine.

The costs for the repair or replacement of parts are in principle always at cost of Steenbeck.

The Steenbeck factory always returns the parts free of charge. The replaced parts are always property of Steenbeck .

If a Steenbeck engineer is required to take care of the warranty repairs or replacements, all travelling and accommodation costs are for the owner/user of the Steenbeck machine.

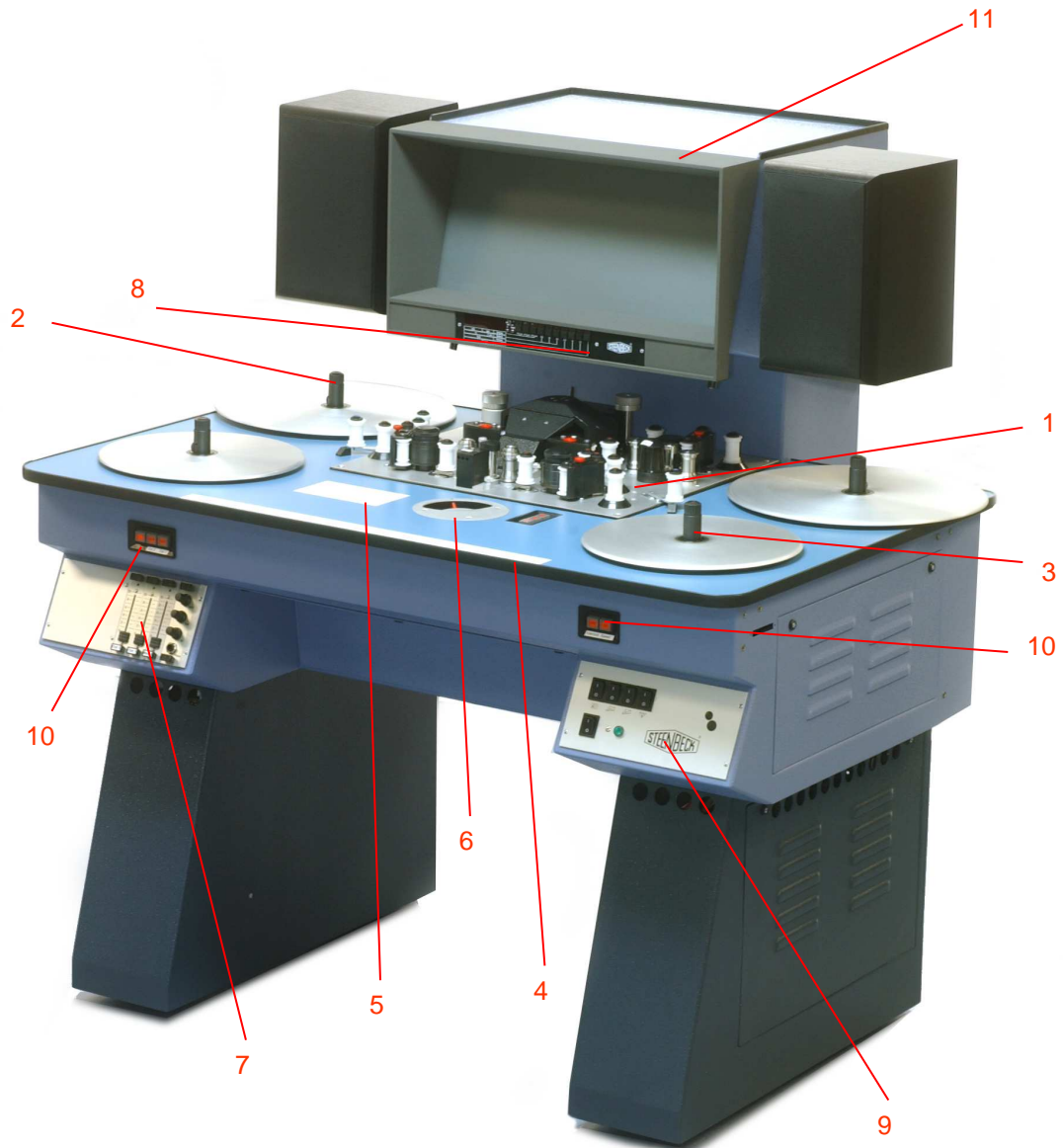

fig.1

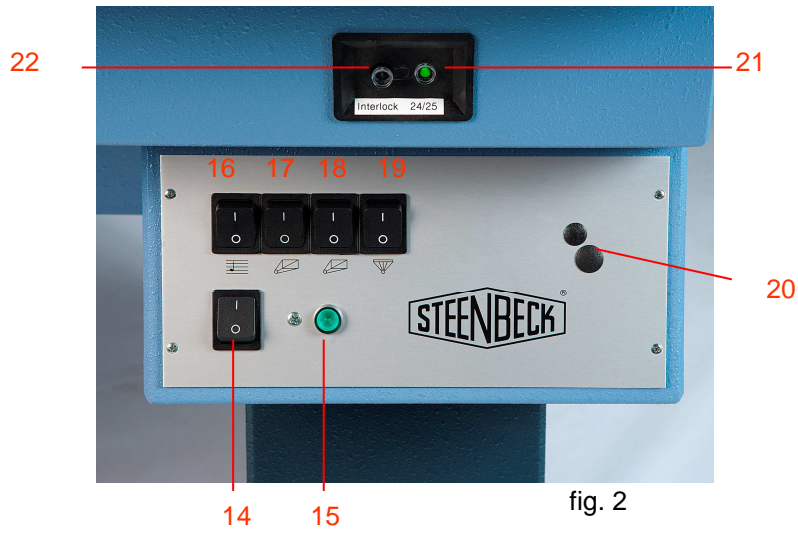

fig. 2

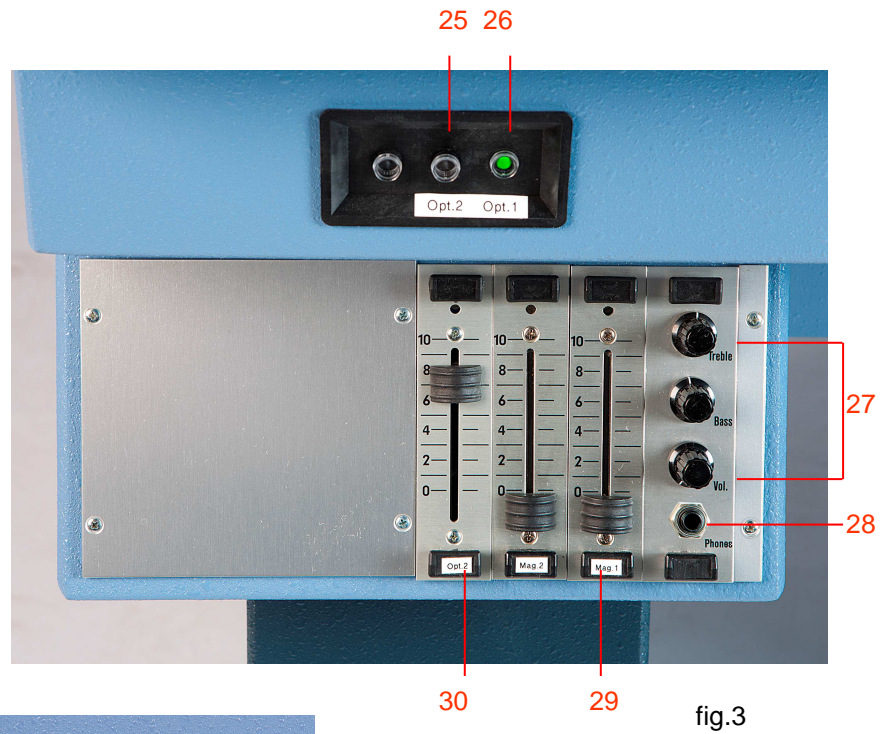

fig.3

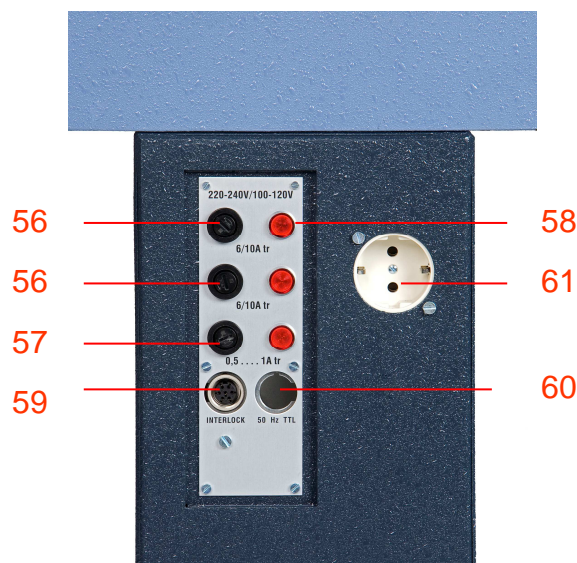
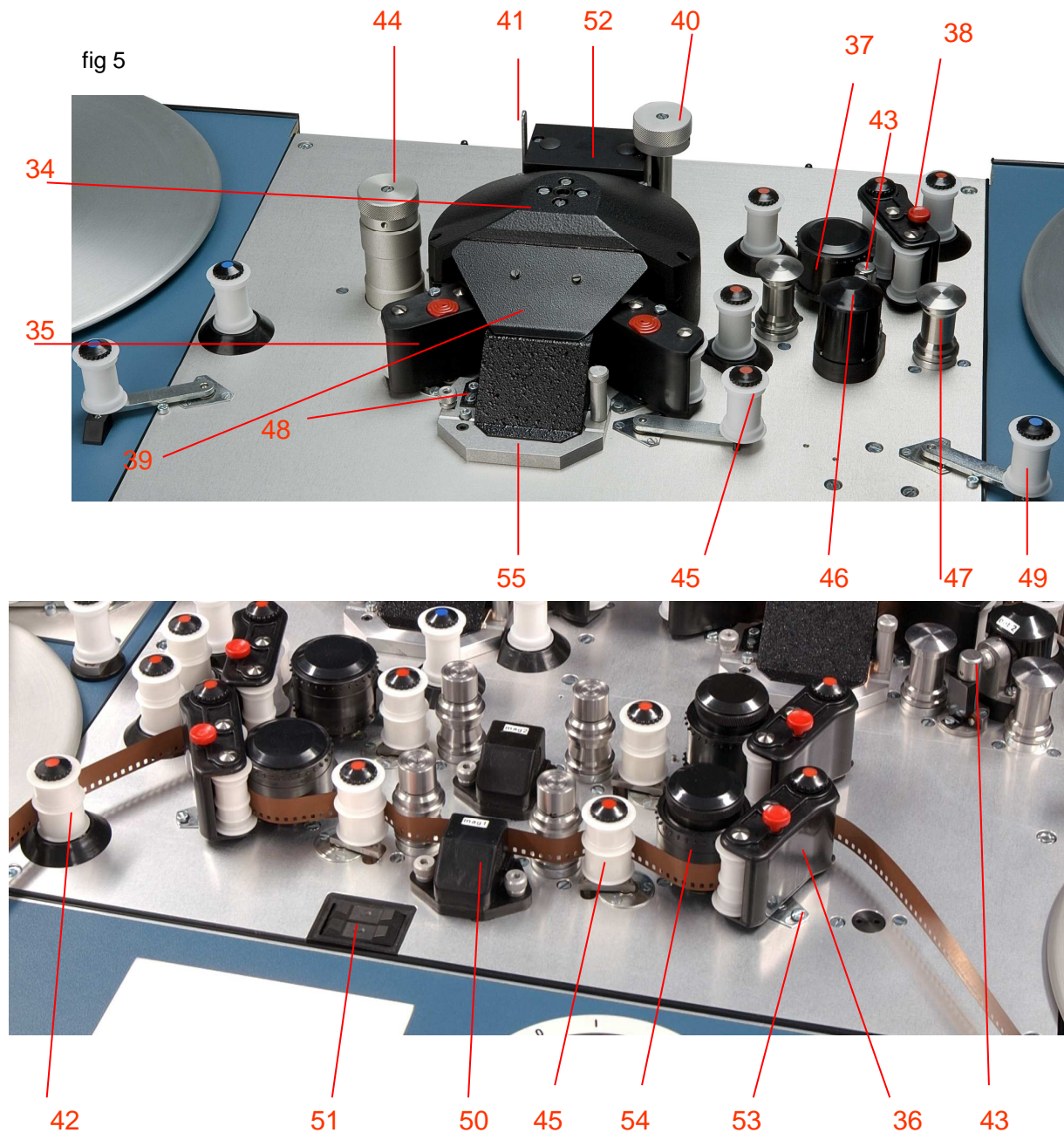

fig.4



5.4 DRIVE DECK OVERVIEW (fig. 5)

- | | |
|--|--|
| <ul style="list-style-type: none"> 34. polygon cover cap (support guide ring; not on photo) 35. pressure arm picture left and right 36. pressure arm sound left and right 37. COMOPT sprocket for film with sound 38. push button (red) to detach pressure arm 39. cover plate (lift when threading film) 40. switcher between standard image and Cinemascope 41. focus image 42. guide rollers film 43. optical sound reader COMOPT 44. knob for framing by hand. (don't touch it while running) 45. tension roller; a) for film with sound b) for SEPMAG sound 46. protection cap optical sound lamp (OPT. 2) 47. fly wheels to optimize sound 48. hexagon screws for adjusting picture lamp (see also page 28) 49. tension arm 50. magnetic head for SEPMAG (or placing SEPOPT / OPT. 1) | <ul style="list-style-type: none"> 51. switch for sound-shift system. ST401-701-721 only 52. lens and prism system 53. screw bearing shaft plate pressure arm 54. SEPMAG / SEPOPT sprocket 55. interchangeable condensor system (part of the illumination system) |
|--|--|

5.0 HOW TO USE THE STEENBECK 35mm 01 - SERIES:

Read this section carefully, study all the possibilities and run some tests.
Make the most important actions your own.

5.1 GENERAL OVERVIEW: (fig. 1 page 9)

- 1 drive deck
- 2 friction left
- 3 friction right
- 4 ruler
- 5 ground glass (back lit), to check film
- 6 speed switch
- 7 sound preamplifier section
- 8 universal counter /display (fig. 15)
- 9 switch board
- 10 pressure switches
- 11 screen holder
- 12 -
- 13 -

5.2 SWITCH BOARD and PRESSURE SWITCHES: (fig. 2 page 10)

Switches 16 t/m 19 are the so-called sub functions.

- 14 main power on / off switch
- 15 pilot lamp
- 16 on / off switch sound
- 17 on / off switch picture lamp
- 18 on / off switch 2nd picture lamp (ST721 only) or switch video lamp
- 19 on / off switch back light ground glass
- 20 rotary knob for dimmer working lamp (optional)
- 21 pressure switch for synchronous speed 24 or 25 f.p.s.
The selected speed is indicated by a green LED on the counter display
- 22 interlock: not in use since 2010
- 23 -
- 24 -

5.3 SOUND PREAMPLIFIER SECTION (fig. 3 page 10)

- 25 pressure switch for optical sound lamp (OPT. 2)
- 26 pressure switch for 2nd optical lamp (SEPOPT – OPT. 1)
- 27 summing amplifier, with treble, bass and master volume control
- 28 headphone ¼" jack (mono)
Don't use a head phone with less than 600 Ohm impedance
- 29 magnetic preamplifier
- 30 optical preamplifier
- 31 -
- 32 -
- 33 -

HOW TO USE THE STEENBECK 35mm 01-SERIES. (continued)

5.4 DRIVE DECK OVERVIEW (2 figures) (fig. 5 page 11)

- 34 polygon cover cap (support guide ring; not on photo)
- 35 pressure arm picture left and right
- 36 pressure arm sound left and right
- 37 COMOPT sprocket for film with sound
- 38 push button (red) to detach pressure arm
- 39 cover plate (lift when threading film)
- 40 switching between standard image and Cinemascope
- 41 focus image
- 42 guide rollers film
- 43 optical sound reader COMOPT
- 44 knob for framing by hand. (don't touch it while running)
For accurate framing it is advisable to operate the editor at a low speed and employ push button 'framing'.
- 45 tension roller; a) for film with sound b) for SEPMAG sound
- 46 protection cap optical sound lamp (OPT. 2)
- 47 fly wheels to optimize sound
- 48 hexagon screws for adjusting picture lamp (see also page 28)
- 49 tension arm
- 50 magnetic head for SEPMAG (or placing SEPOPT / OPT. 1)
- 51 switch for sound-shift system. ST401 - ST701 – ST721 only.
- 52 lens and prism system
- 53 screw bearing shaft plate pressure arm (see also page 23)
- 54 SEPMAG / SEPOPT sprocket
- 55 interchangeable condensor system (part of the illumination system)
(see also fig. 12 page 29)

5.5 FUSE PANEL: at the back of the right hand leg (fig. 4 page 10)

- 56 fuse 6,3 Amps T (220 / 240 volts) or 10 Amps T (110 / 120 volts)
- 57 fuse 0,5 Amps T for all voltages or 1 Amp T (110 / 120 volts)
- 58 pilot lamp fuses. (on when a fuses is blown)
- 59 Interlock (not in use with 01-Series, from 2010 onwards)
- 60 bi-phase (not in use with 01-Series, from 2010 onwards)

The fuses are located in a holder with bayonet mount.
If a fuse has blown, the pilot lamp (39 page 10) next tot his fuse will be on.

HOW TO USE THE STEENBECK 35mm 01-SERIES. (continued)

5.6 connecting to mains power:

Connect the machine to the power network according to the instructions on page 5 with the supplied power cable. Make sure that this cable is well connected. Always check the Voltage and Frequency mentioned on the type and serial number plate (back side table).

Of great importance is a safe power ground system.

Switch the 01-Series on with the main switch (fig.2 #14 page 10), it shows a green light.(15)

Only then switch on the sub functions (from 16 onwards).

Warning : before switching off the table, always switch off all the sub functions.

5.7 Threading film:

Thread 35mm film according to pages 30 - 34

Attention: in order to prevent unnecessary wear, when threading film without sound, never use the magnetic head (fig. 5 #50 page 11) and sprocket (37), and switch off the sound (fig. 2 #16 page 10).

When the film has COMOPT sound, thread the film with sprocket (37) in a way the tension roller (45) can move a little bit, this because too much tension can damage the perforation.

Use the speed switch (fig 1 #6 page 9) to view the film.

While winding or rewinding from 0 to sync speed and sync, the speed is continuously variable.

This makes it possible to view the film frame by frame.

When the framing is not correct it can be adjusted (see pages 25 - 28).

Focus picture is adjustable (fig.5 #41 page 11).

Thread the 35mm film according the version.

Pages 30 - 34 show the way to thread film with and without sound.

Also shown are the threading of SEPMAG / SEPOPT.

HOW TO USE THE STEENBECK 35mm 01-SERIES. (continued)

5.8 Rewind:

Don't rewind the film as it is thread for viewing, because of the sprockets, older films with bad splices and perforation can get damaged.

It's advised to rewind the film always with a (Steenbeck) film rewinder.

The Steenbeck film rewinder can wind forward and backward and the speed can be adjusted, even to very slow. This can be useful when it's required to check or clean the film by hand.

5.9 Sound:

The 35mm film can be viewed with optical (COMOPT) sound and separate magnetic sound (SEPMAG).

See for threading film with COMOPT sound and SEPMAG sound pages 30-34.

Hints for optical sound:

- if optical is unused, it's preamplifier fader should be set to **zero** position.
- avoid direct exposure of the optical sound reader by room light or table working lamp. The light sensitive device in the sound reader may be influenced by this exposure and causing extra audible noise like hum.

Adjustment of the volume with the fader halfway on the preamp first.
(page 10 #29 – 30)

Then the master volume control button (page 10 #27) in the mid .

Adjustment of the sound by treble and bass (page 10 #27)

Plug in a headphone with a '1/4"jack' (page 10 #28).

When a headphone is used, the speakers are off.

Caution:

When the level of the headphone is too low, it's caused by the impedance of the headphone

6.0 Universal counter:

For ST3511 – ST(1)401 – ST701 – 2nd counter ST721.



The Steenbeck universal counter is designed to measure film length (all formats) and calculate the position and time information in common use. Additionally, the universal counter may offer extra possibilities for more effective work on your film rewind / film inspection table.

The counter / calculator functions are controlled by keys No. 1 – 10 (right to left)

- | | | |
|-----|------------------|---|
| 1. | frames | counts and displays number of frames (max. 1.999.999) |
| 2. | feet 35mm | displays film length in feet (16 frames = 1 foot) |
| 3. | feet 16mm | displays film length in feet (40 frames = 1 foot) |
| 4. | feet 8Smm | displays film length in feet (72 frames = 1 foot) |
| 5. | m / dm 35mm | displays film length in meters (1 meter = 52,630 frames) |
| 6. | m / dm 16mm | displays film length in meters (1 meter = 131,200 frames) |
| 7. | m / dm 8Smm | displays film length in meters (1 meter = 236,200 frames) |
| 8. | min / sec 25 FPS | displays elapsed time (1 second = 25 frames) |
| 9. | min / sec 24 FPS | displays elapsed time (1 second = 24 frames) |
| 10. | min / sec 18 FPS | displays elapsed time (1 second = 18 frames) |

The two digits to the right always indicate numbers of frames.

The other digits show the counter value according to the chosen film format.

A red LED on the key indicates the activated display format.

The green LED indicates 24 or 25 frames per second sync speed of the editor.

Together with the keys you will find one switch and two pushbuttons on the counter front panel.

- | | |
|----------------------|--|
| Pushbutton C = Clear | Counter is reset to ZERO. |
| Pushbutton HOLD | Display is stopped at actual reading.
The counter keeps on counting. When releasing Pushbutton , counter value is transferred to display. |
| Switch DIST CTR | Setting 1: distance counter on
Setting 0: distance counter off.
The distance counter is activated to measure partial length or time values.
It can be reset to ZERO (C) without effecting the main counter. |

UNIVERSAL COUNTER PICTURE – SOUND SHIFT SYSTEM.

For ST401 – ST701 – ST721

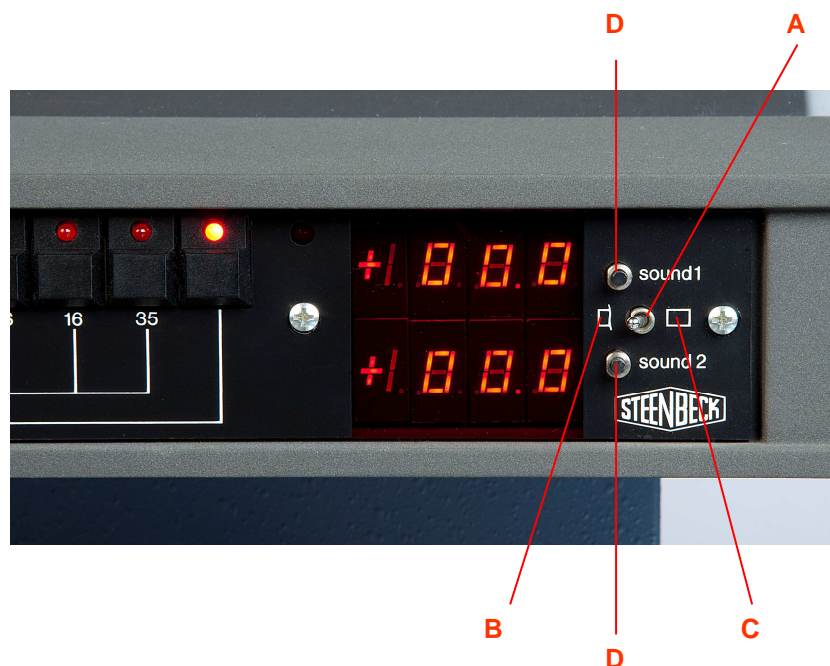

The picture-sound synchronizer shows the shift of the sound tape against the picture tape in positive and negative directions. The range of display is ± 99.9 frames. The shift of the sound tape is accurate tot 1/100 of a frame – displaying are 1/10 of a frame.

A switch **A** makes two type of operation possible:

Switch position **B**:

As long as the switch 51 (fig. 5 page 11) is pushed the picture – sound shift runs continuously and can be stopped at any desired point.

Thus both tapes can (with a ST701-ST721) be brought together with perforation correct at the sync point.

For ST401 one display is in function.

Switch position **C**:

With every touch of the switch 51 the sound tape be moved forward or backward by exactly one frame, e.g.: to bring forward the sound by ten frames, the switch in a forward position has to be momentarily pressed ten times.

By prolonged pressing the tape will carry on till the key is released.

The tape will now exactly to a perforation.

This will avoid the troublesome forward and backward pulling of the tape to synchronize the two.

Push buttons **D** : reset display.



ST701

7.0 Connecting loudspeakers and (optional) working lamp:

All connections at the back of the frame.

Work light: (fig.)

Connector for 230V light max. 60 Watt.

The connection is as follows:

230 Volt: pin 1 = phase + / pin 2 = phase - / pin 3 = ground

8.0 MAINTENANCE INSTRUCTIONS.

With the 01-Series delivered tools and spare parts which also can be ordered separately:

	part number:
Tools:	
1 x wrench M2,5 to adjust frictions	9962.0088.00
1 x hexagon M4 to adjust picture lamp	9962.0087.00
Cleaning brush	N000.0473.00
Cleaning cloths set (blue and yellow)	N000.0521.00
Spare parts:	
2 x picture lamp 12V- 100W	9956.1066.00
1 x exciter/optical sound lamp	9956.1080.00
10 x fuse 6,3 Amp. T (5 x 20 mm)	9956.0232.00
10 x fuse 0,5 Amp. T (5 x 20 mm)	9956.0224.00
Various:	
Dust cover	9962.1083.00

8.1 Introduction.

The Steenbeck 01-Series doesn't need much maintenance. It depends on by whom, how and under what circumstances the table is used. It's advised to clean the table every time it has been used with the supplied brush.

Clean the top of the table with the supplied cloth; Start cleaning with a moist microfiber cloth (Blue) and dry it with the (Yellow) dry cloth.

Caution: technical maintenance.

When the Steenbeck 01-Series is regularly in use (almost daily basis and more) the maintenance needs to be done at least once a year by the dealer or Steenbeck factory engineer. In this service the table will remain in a good condition.

To facilitate the operation the following instructions should be strictly adhered to. (pages 19 – 23)



= only done by skilled staff

Before opening the machine be sure it is disconnected from the mains.

Only service engineers are authorized to do adjustment and technical maintenance.

The machine should only be operated with the side and front panels closed.

8.2 Replacing the picture lamp.

The interchangeable condenser system (fig. 5 #55 page 11) encloses the picture lamp.

Remove both nuts besides the system and remove carefully the system.

Take out the lamp and the new one is carefully and gently pressed into the lamp socket.

ALWAYS readjust the newly inserted picture lamp.

NEVER touch the bulb with your fingers or clean it with a chemical alcohol.

Replace the condenser system carefully and pay attention to the contacts in the ground plate and the female contacts in the drive deck.

8.3 Replacing of exciter lamp / optical sound lamp.

Remove protection cap (fig. 5 #46 page 11), loosen screw behind exciter lamp,

Before taken out the broken exciter lamp, check how it was placed. (lamp filament)

Take out old exciter lamp.

Replace new lamp the same as the broken came out.

Turn it in order to gain maximum illumination through the light gap, which is tested by running film with optical sound.

Now tighten screw gently and put protection cap on.

8.4 Adjustment of pressure arms picture.

Feed two film strips through the sprocket and counter press arms.

Loosen screws at the bearing shaft plate (#53 – page 23) and change pressure of the arm so that both guide rollers are under the same pressure. Now tighten screws.

Loosen fixing screws of locking pin. Turn it, so that there is no play between film and guide roller. Tighten fixing screws.

As pressure arms are adjusted for two thicknesses of film by manufacturer, readjustment is only necessary after dismantling of the bearing shaft or the locking pin.

Maintenance of optical parts.

8.5 Surface-coated mirrors.

Cleaning may only be done with a soft lens brush or lens cloth.

If the mirror is very dirty, detach it and clean carefully with clear water and cotton wool. To avoid water stains the final touch is made with dry cotton wool.

8.6 Polygon and lens.

If the polygon is just a slightly soiled, open the pressure arms from the front and clean with soft leather, cotton or special optician's tissue.

For more thorough cleaning the support of the upper film guide support can be removed (fig. 5 #34 page 11)

For this purpose remove at first the cap from the objective and prism (fig. 5 #52), then loosen the 4 screws of the support and the upper film guide support can be taken off.

One has free access to the polygon now,

When remounting the support be sure the surface of the base is clean, otherwise the upper film guide and sprocket ring do not line up.

The objective and prism can only be cleaned with the housing removed.

This should be done by a Steenbeck engineer only because of optical alignment of the projected image.

8.7 Screen.

The surface of the synthetic material is sensitive and can easily be scratched. It is advisable to clean the screen regularly with a soft cloth. If more cleaning becomes necessary, unscrew the screen from the screen holder (fig.1 #11) and clean it with water.

Caution: -do not use any chemicals.
-pull the counter flat cable plug before removing the screen (holder).

8.8 illumination system.

The upper prism and its lenses (interchangeable condenser #55 – fig. 5 page 11) can be unscrewed and cleaned in the same manner as the revolving prism (polygon). See 8.5 – 8.6.

8.9 Frictions. (take up and supply units)



Frictions are operated by a motor via multiple V-belts. It may become necessary to adjust the belt tension after a certain operating time.

To achieve this, open frame on both sides and loosen the corresponding tension roller arms with a wrench for 5mm bolts (8mm) and adjust the belt tension.

The wind pull of the centre cores can be adjusted with the little tension bolt inside the square mandrel (8mm) of each friction.

For readjustment take off the film core. The tension bolt can be turned then by an allen key (hexagon) 2.5mm Steenbeck part number 9962.0088.00.



When turning **anticlockwise** the wind pull will be more firm.

When turning **clockwise** the wind pull becomes looser.

The square 8mm mandrel must be arrested with a 8mm wrench.

(Steenbeck part number N000.0471.00)

The wind pull should be checked by means of a 100 core and a spring scale.

In running mode (sync) of the table it should be as follows:

35mm picture:	approx. 1.0 – 1.2 N	/	100 – 120 grams.
35mm sound:	approx. 0.8 – 1.0 N	/	80 - 100 grams.

Caution: this is an advise and other adjustments should be made regarding old, shrunken or twisted material.

The core plate of the friction should not be greased or lubricated at the bottom.

The core axle fig.a should be greased a little bit.

The film plate support fig.b (plastic ring friction plate / inner ring film plate fig.c) should have some Vaseline. (Steenbeck part number N000.0472.00)

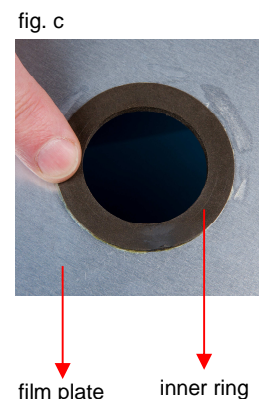
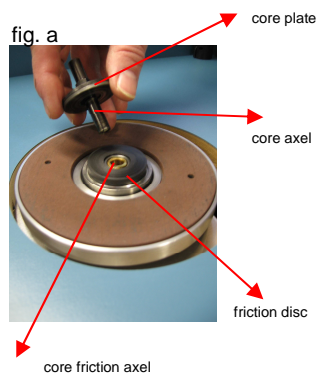

If **metal** film reels are used, the film plates and film core holders have to be taken off. The film reel is then placed upon the remaining square mandrel. This is only for 16mm film reels according ANSI PH 22.11 – 1981). You might have to readjust the frictions because the weight of the film reels (see above).

Caution: do not use a film reel with a core diameter less than 50 mm, as otherwise the film material could be damaged.

8.10 General maintenance.

Remove dust, scrapping and film remainders from the machine **DAILY**.

After every approx. 100 hours of operation:

Clean all guide rollers, pressure arms/rollers and sprockets from possible remainders of film and **tape**.

For cleaning the teeth of sprockets use a **wooden** stick.

Never use steel tools.

After every approx. 500 hours of operation:

Take off all rollers, clean rollers, shaft of rollers and axles with cleaning solvent.

Grease slightly the axles and shaft with a highly fluid oil.

After every approx. 1000 hours of operation:

Change motor oil in gear box as follows:



-open the middle panel of the chassis.

(near your knees when sitting behind the table)

-look for the drain screw at the bottom and the filling screw at the top of the gear box.

Loosen both screws. Empty the old oil into a container.

After tightening of the drain screw refill the box with new oil ATF, approx.. 22cc.

An elapsed time counter is available as an option. (Z50)

8.11 Adjustment guide ring 35mm.

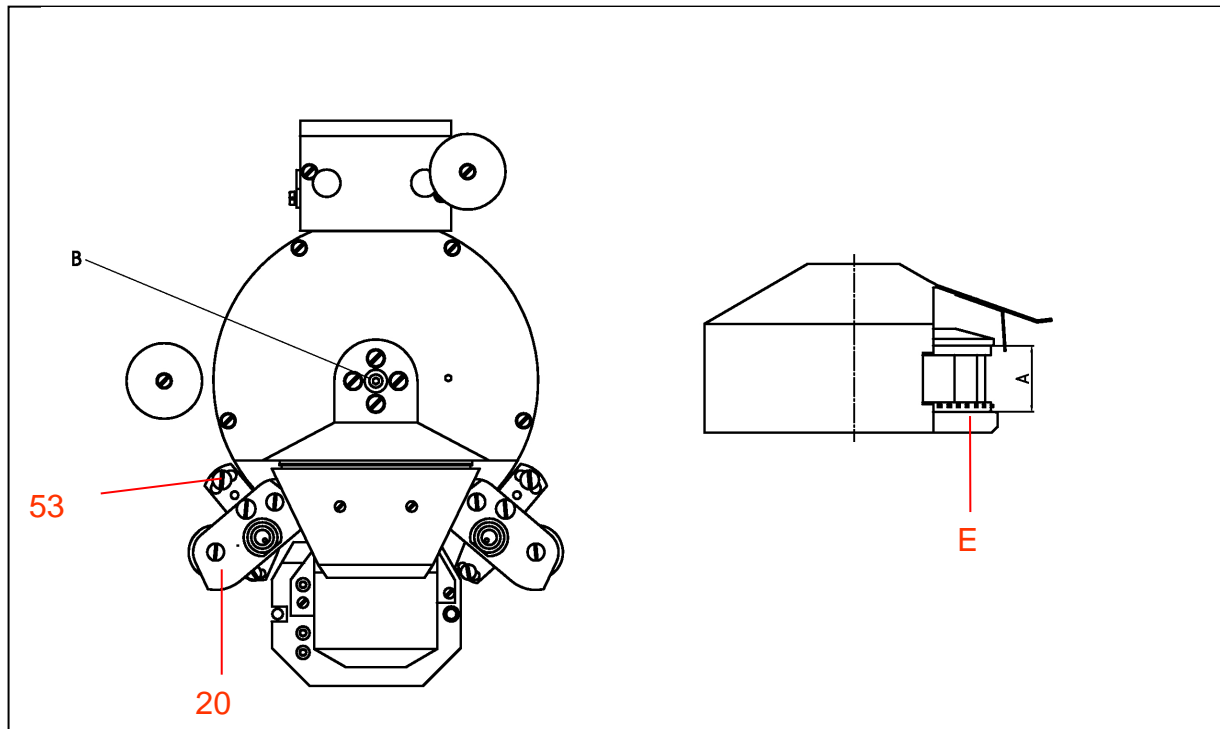

Old film, even new film can differ in width.

The width "A" is normally set to 35mm – 0,2mm.

If the film is bending on the film gate the width must be adjusted.

The screw "B" (hexagon 4mm) should be turned:

- a) gate larger: anticlockwise b) gate smaller: clockwise

If the film is loose on the gate (horizontal picture jitter), the screw "B" should be turned clockwise.

Caution:

With old film be careful to make alignments.

Extra attention should be given when shrunken film is in the gate.

Try first to use one of the two picture pressure arm (20).

Make a careful test.

When this is not really helping the sprocket ring (E) should be replaced.

9.0 LIST OF SLOW / FAST MOVING PARTS 35mm 01-Series.

Fast moving parts:

Part number	
9956.0224.00	fuse 0,5A T (slow)
9956.0232.00	fuse 6,3A T
0056.0230.00	fuse 2,0A T
9956.0227.00	fuse 1,0A T
9956.1066.00	picture lamp, 12 V / 100W
9956.1080.00	sound exciter lamp

Slow moving parts:

Part number		
0309.0202.01	picture roller, picture 35mm	(2)
0309.0201.01	pressure roller, picture 35mm	(1)
1010.0203.01	guide roller picture 35mm	(7)
2808.0202.01	pressure roller picture (for sound) 35mm	(4)
2808.0201.02	pressure roller sound 16/17,5mm	(3)
1010.0803.01	sound roller (S)16/17,5mm	(10)
1010.0204.01	sound roller 35mm	(8)
9953.0532.00	picture lamp socket	
9955.0080.00	motor brush	

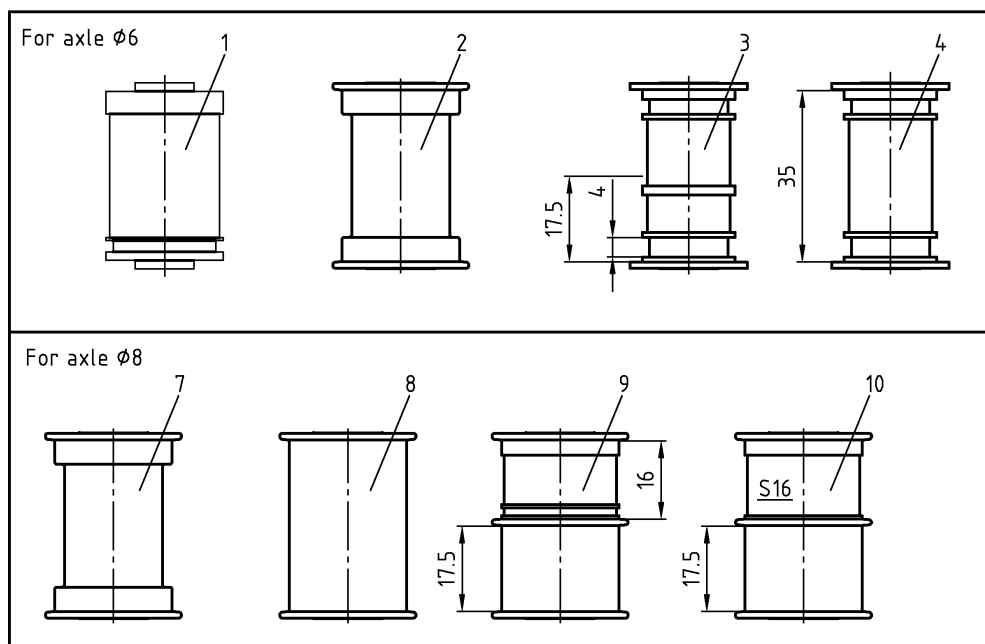

10.0 OPERATION FIELD TABLE TOP.

10.1 SPEED SWITCH ST3511

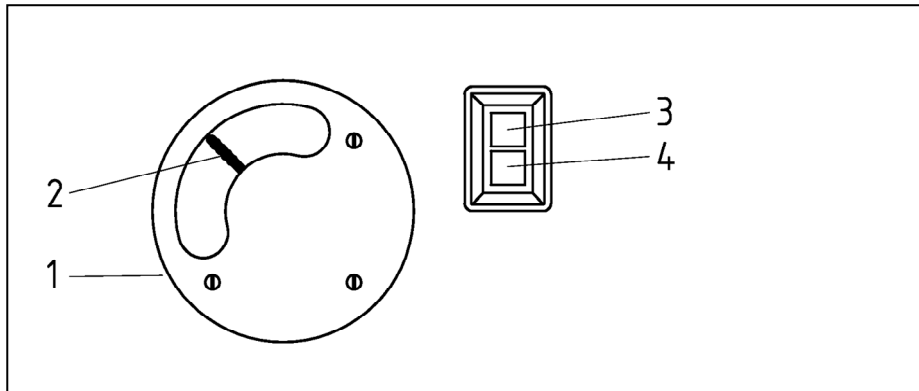

fig.8

1. Speed selector (1) is activated by the speed control lever (2) in both directions.
 - first notch right; sync speed forward.
 - second notch right: winding speed forward, approx. 2/3 of maximum speed.
 - first notch left; sync speed revers.
 - second notch; winding speed revers, approx. 2/3 of maximum speed.
 - final notch in both directions; maximum speed, approx. 200 frames per sec..

Between standstill and maximum speed forward or revers the speed is fully variable by hand.

2. Speed control lever.

3. Framing picture

4. Framing picture

OPERATION FIELD TABLE TOP.

10.2 SPEED SWITCH ST(1)401

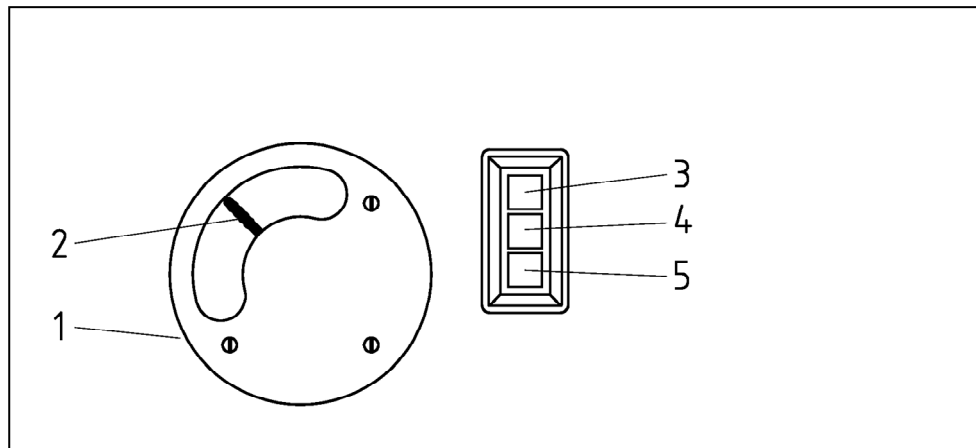

fig. 9

1. Speed selector (1) is activated by the speed control lever (2) in both directions.
 - first notch right; sync speed forward.
 - second notch right: winding speed forward, approx. 2/3 of maximum speed.
 - first notch left; sync speed revers.
 - second notch; winding speed revers, approx. 2/3 of maximum speed.
 - final notch in both directions; maximum speed, approx. 200 frames per sec..

Between standstill and maximum speed forward or revers the speed is fully variable by hand.

2. Speed control lever.

3. Clutch and brake switch for picture (track 1)

4. Clutch and brake switch for sound Mag. 1 (track 2)

5. Framing

Clutch and brake switches 3 and 4 are used to (dis)-engage the corresponding tapes from the drive.

Push button released: tape engaged.

Push button suppressed: tape disengaged.

Remark:

As soon as the table runs the switches 3 and 4 are enabled. (except 5: framing)
After the tables has stopped, these switches can be used again.

This feature is for:

- no damage can be done to material while the editor is in a full wind speed.
- no loss of sync by pushing clutch/brake switch accidentally during viewing.

OPERATION FIELD TABLE TOP.

10.3 SPEED SWITCH ST701

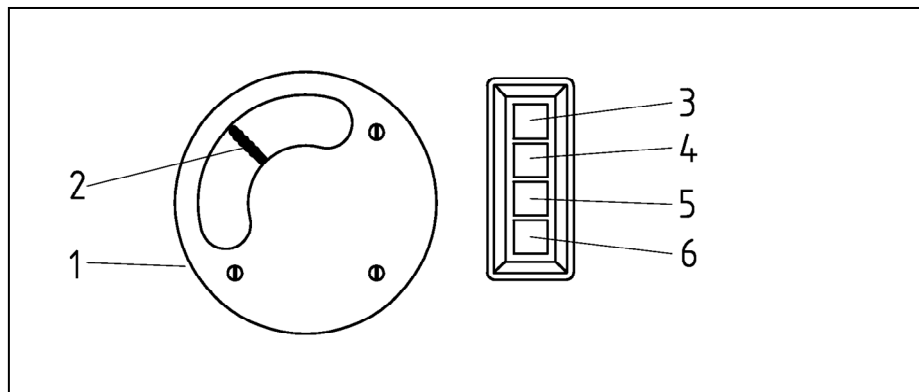

fig.10

1. Speed selector (1) is activated by the speed control lever (2) in both directions.
 - first notch right; sync speed forward.
 - second notch right: winding speed forward, approx. 2/3 of maximum speed.
 - first notch left; sync speed revers.
 - second notch; winding speed revers, approx. 2/3 of maximum speed.
 - final notch in both directions; maximum speed, approx. 200 frames per sec..

Between standstill and maximum speed forward or revers the speed is fully variable by hand.

2. Speed control lever.

3. Clutch and brake switch for picture left (track 1).

4. Clutch and brake switch for picture right (track 2).

5. Clutch and brake switch for sound Mag.1 (track 3).

6. Framing

Clutch and brake switches are used to (dis)-engage the corresponding tapes from the drive.

Push button released: tape engaged.

Push button suppressed: tape disengaged.

Remark:

As soon as the table runs the switches are enabled. (except 6: framing)

After the tables has stopped, these switches can be used again.

This feature is for:

- no damage can be done to material while the editor is in a full wind speed.
- no loss of sync by pushing clutch/brake switch accidentally during viewing.

10.0 OPERATION FIELD TABLE TOP.

10.4 SPEED SWITCH ST721

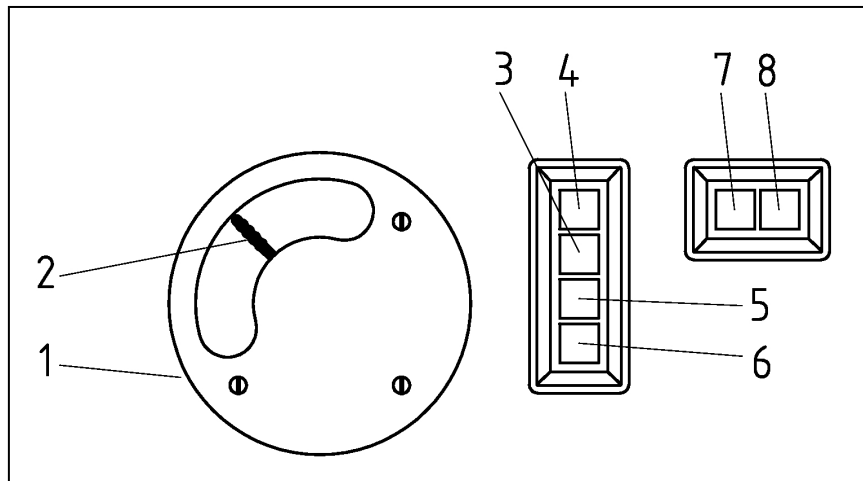

fig.11

1. Speed selector (1) is activated by the speed control lever (2) in both directions.
 - first notch right; sync speed forward.
 - second notch right: winding speed forward, approx. 2/3 of maximum speed.
 - first notch left; sync speed revers.
 - second notch; winding speed revers, approx. 2/3 of maximum speed.
 - final notch in both directions; maximum speed, approx. 200 frames per sec..

Between standstill and maximum speed forward or revers the speed is fully variable by hand.

2. Speed control lever.

3. Clutch and brake switch for picture left (track 1).
4. Clutch and brake switch for picture right (track 2).
5. Clutch and brake switch for sound Mag.1 (track 3).
6. Clutch and brake switch for sound Mag.2 (track 4).

7. Framing picture left
8. Framing picture right

Clutch and brake switches are used to (dis)-engage the corresponding tapes from the drive.

Push button released: tape engaged.
 Push button suppressed: tape disengaged.

Remark:

As soon as the table runs the switches are enabled. (except 6: framing)
 After the tables has stopped, these switches can be used again.

This feature is for:

- no damage can be done to material while the editor is in a full wind speed.
- no loss of sync by pushing clutch/brake switch accidentally during viewi

11.0 ADJUSTMENT PICTURE LAMP 35MM.

ST3511 / ST(1)401 / ST701 / ST721

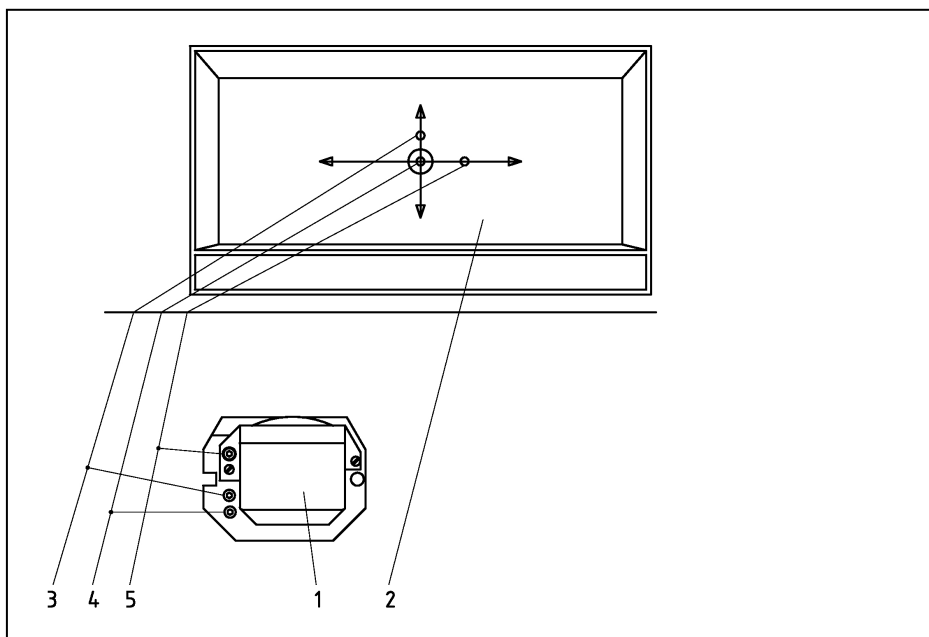
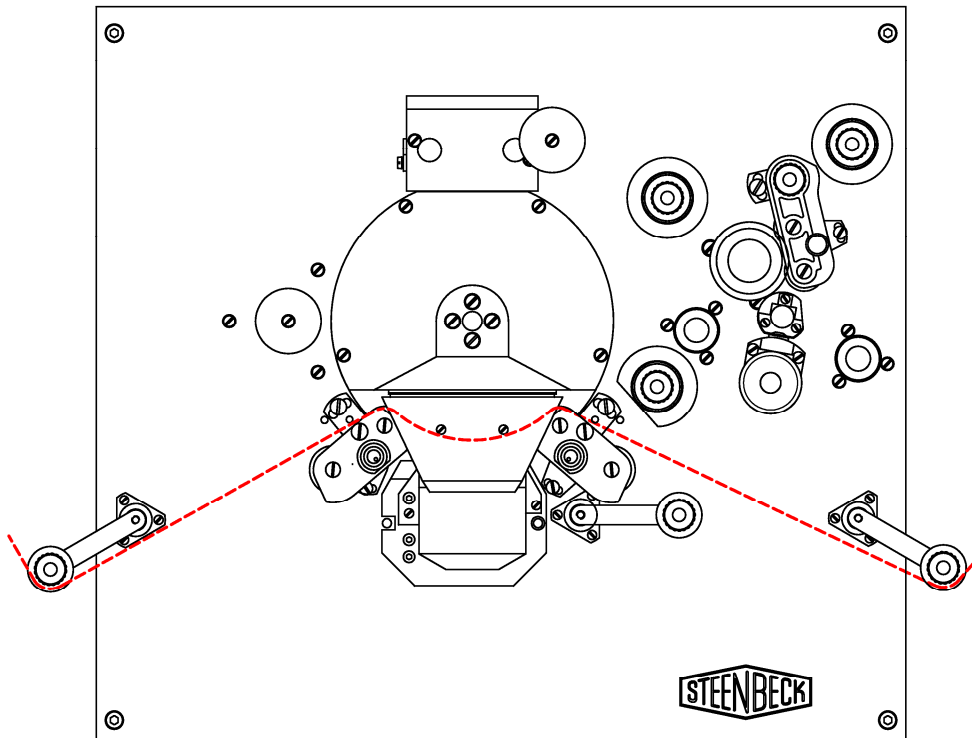

fig.11

1. Lighting aperture (interchangeable condensor system)
2. Picture screen
3. Adjusting screw, **vertical**.
For uniform illumination at the top and bottom of the screen.
4. Adjusting screw, **focus**.
Adjusting to minimal flickering
5. Adjusting screw, **horizontal**.
For uniform illumination to the left and right of the screen.

Picture lamp adjustment should be carried out with machine in operation in sync speed, but without film. It is advisable to start with the screws 3 and 5.
Use Hexagon 4mm Steenbeck part number

ST3511 picture only



ST3511 picture with optical sound COMOPT

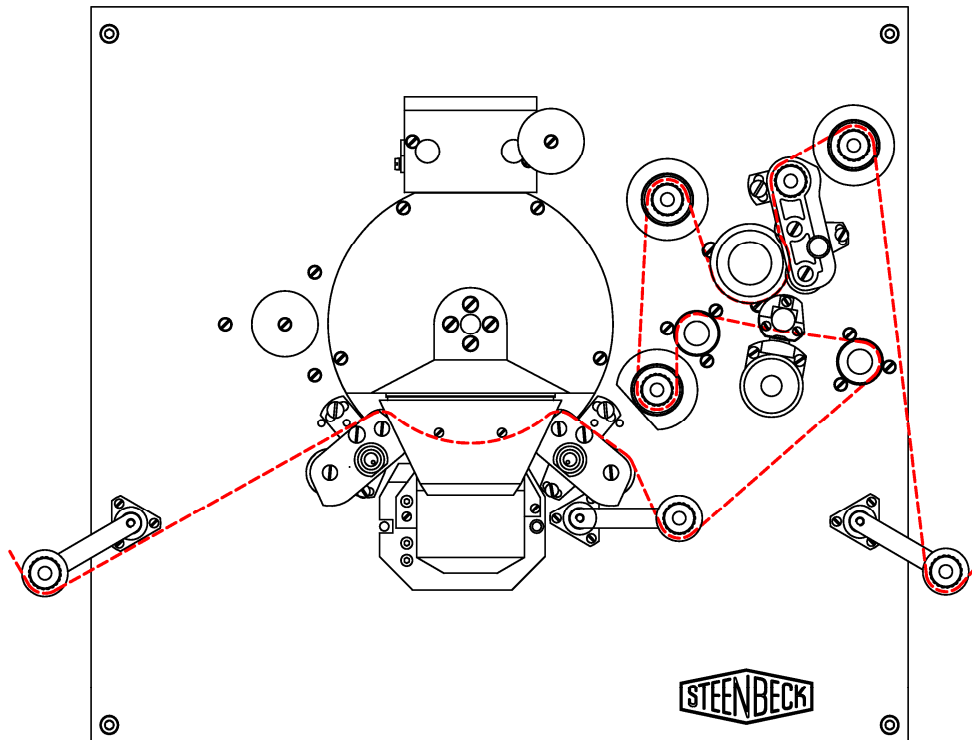

ST1401 picture w/o sound with SEPMAG

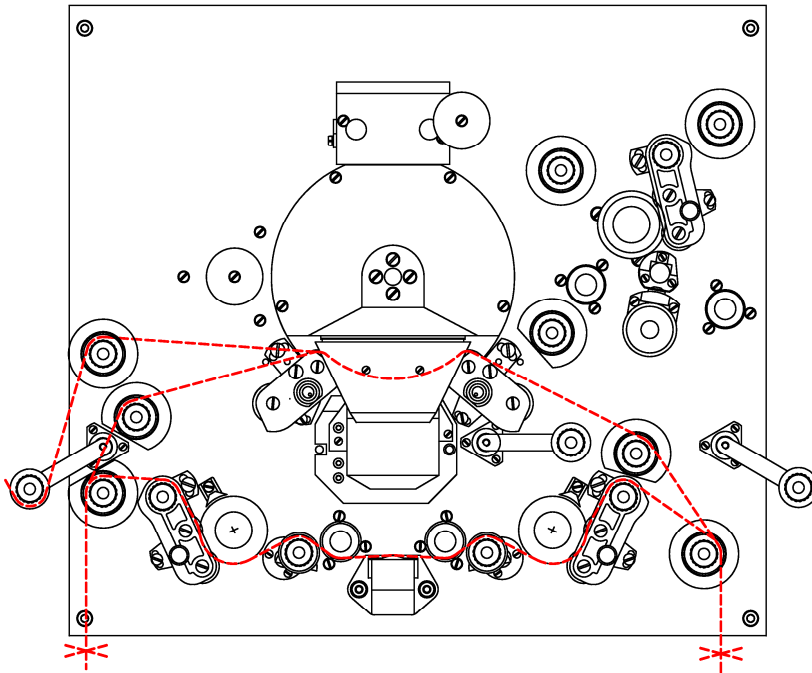

ST1401 picture with optical sound COMOPT

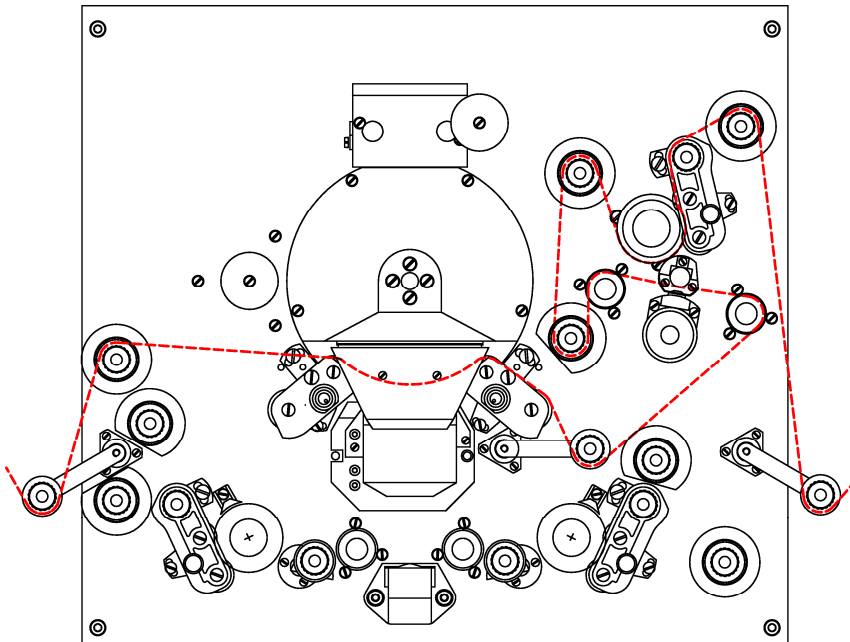

ST1401 picture with COMMAG sound

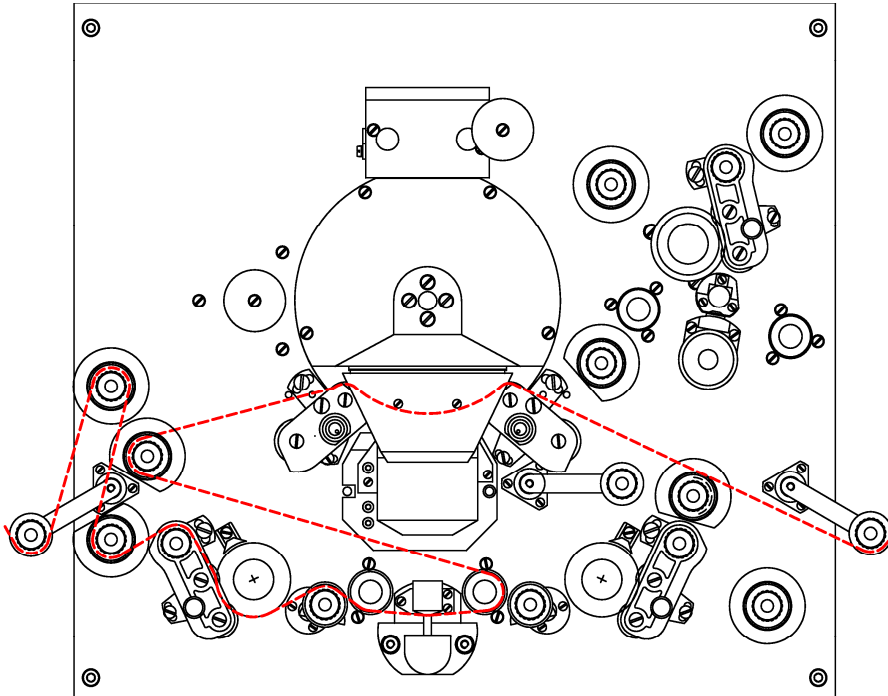

COMMAG only with special replay head, 2 and 4 track

ST701 picture with optical sound COMOPT

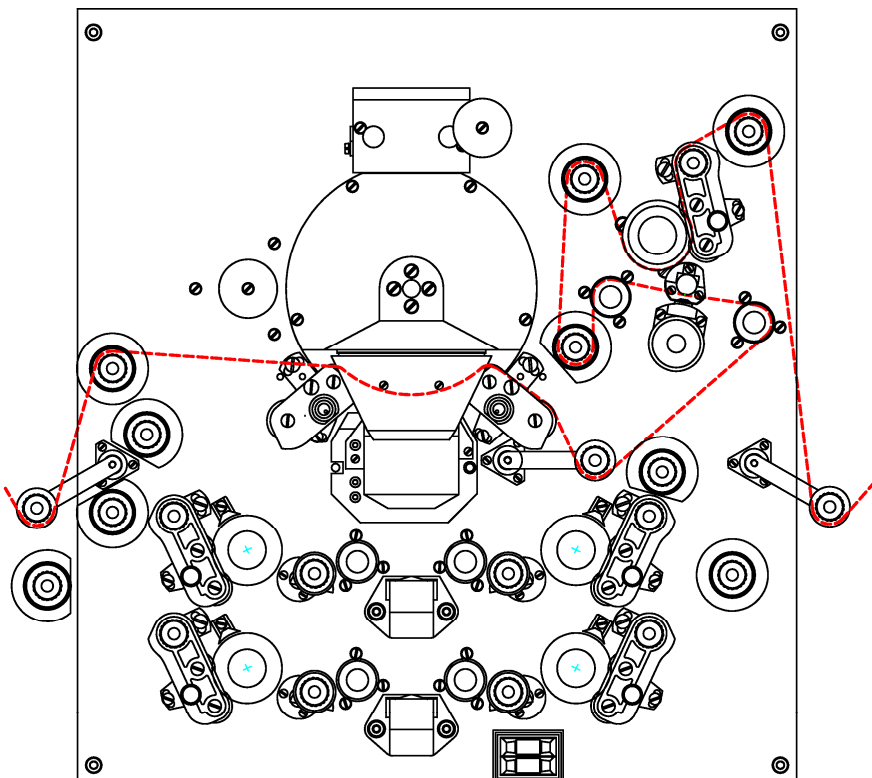

ST701 picture w/o sound, SEPMAG sound

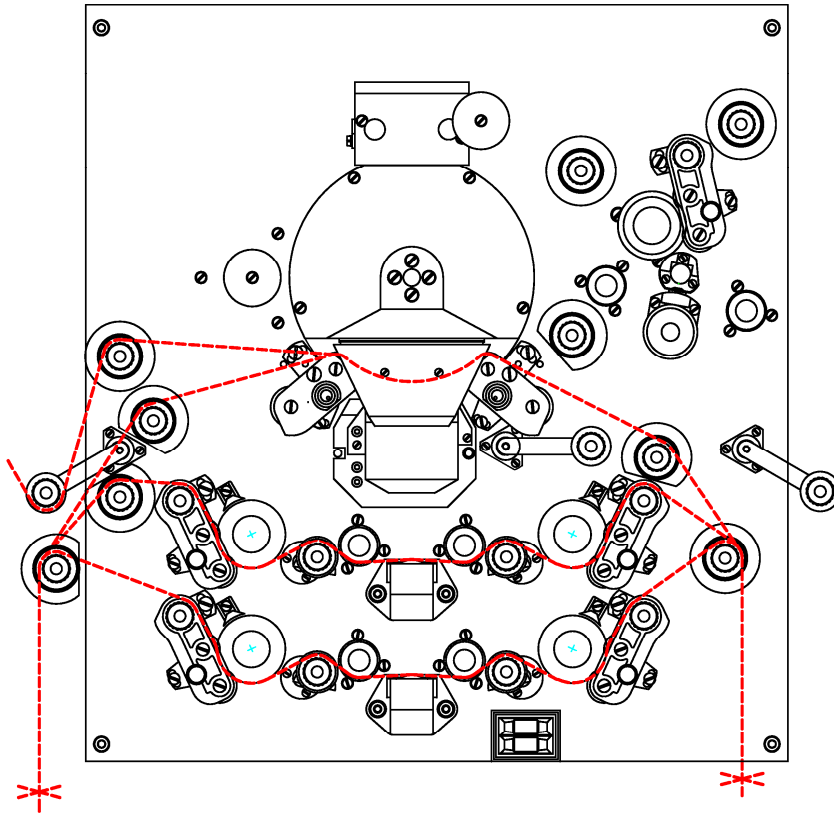

ST721 L picture w/o sound R picture with optical sound

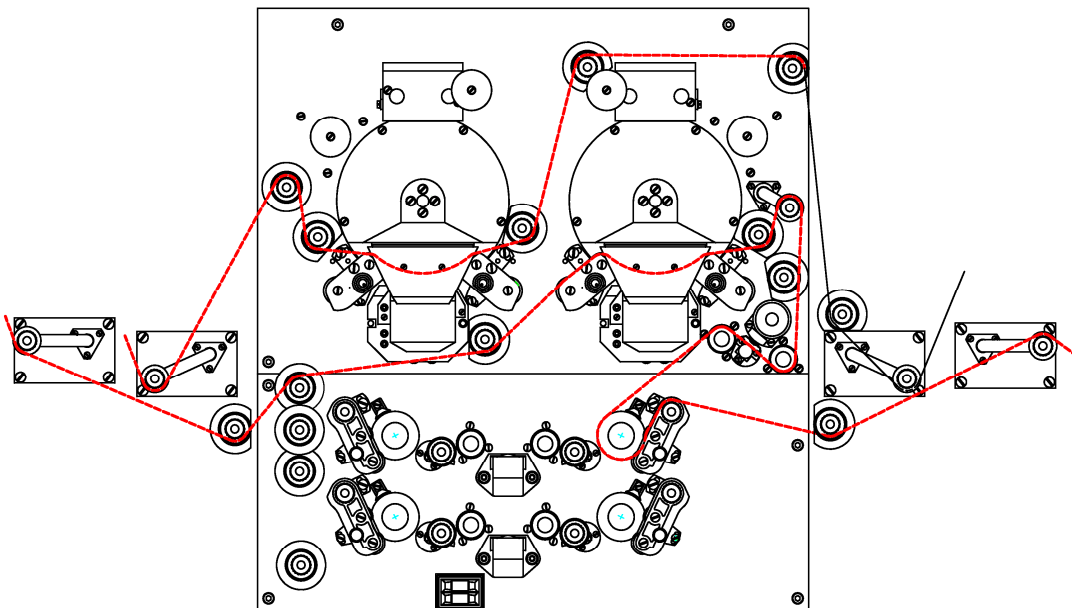

ST721 pictures w/o sound / SEPMAG sound

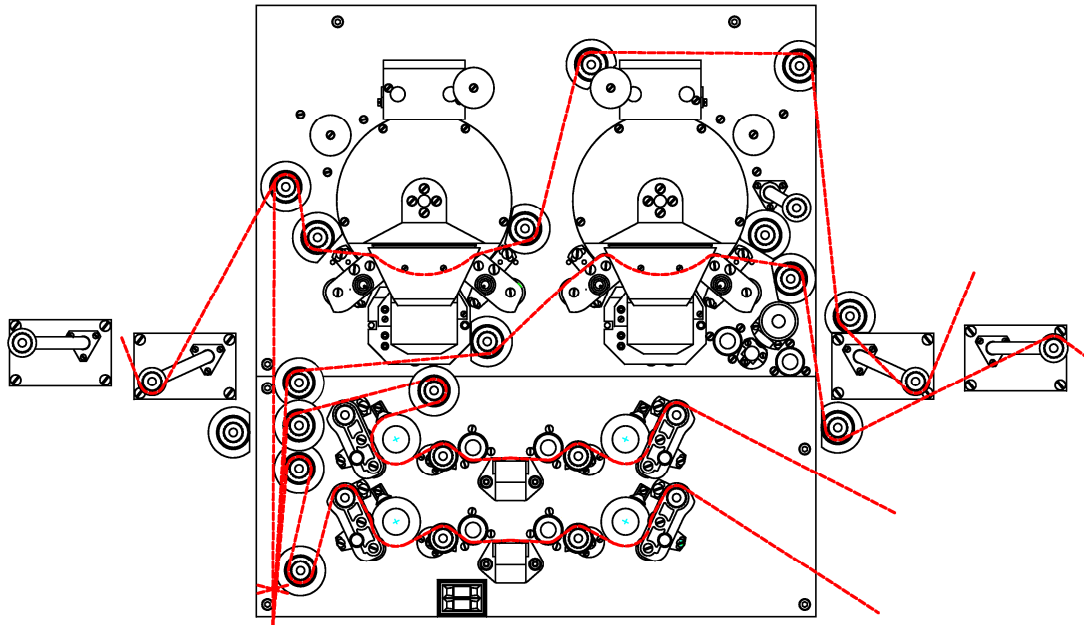



ST701



ST721
with optional video

STEENBECK B.V. (Ltd.)
Keizersveld 31, 5803 AM VENRAY. The Netherlands
Tel: +31 (0)478 63 03 00 Fax: +31 (0)478 69 00 07
info@steenbeck.com www.steenbeck.com